



## **Ski Spectacular Instructor Academy**

**Hosted by The Hartford Ski Spectacular  
December 4-8, 2022  
Clinic Summary Notes**

**Clinic Topic:** Tips and Tools for Teaching Guests with Autism - Ryan Latham

1. Try to be predictable and consistent. Collaborate as much as possible with the student on what the goals and outcomes of the day are intended to be. Use supports and aids as needed.
2. Autonomy is critical. Allowing the learner to have as much input as possible on their experience is invaluable to learning outcomes. Giving choices to the experience as needed can reduce anxieties and increase participation.
3. Using tools can make a difference in the lesson. Understanding why you are incorporating a tool is imperative. Each tool has its value but can also create its own consequences.
4. Positive reinforcement is usually better than negative reinforcement. Collaborate with the guest and any caregivers/parents before utilizing negative reinforcements.

**Resources:** <https://www.thesnowpros.org/education/digital-manuals-for-every-discipline/>

*PSIA Adaptive Alpine Technical Manual; Pages 50-65*

*PSIA AASI Teaching Children Snowsports*

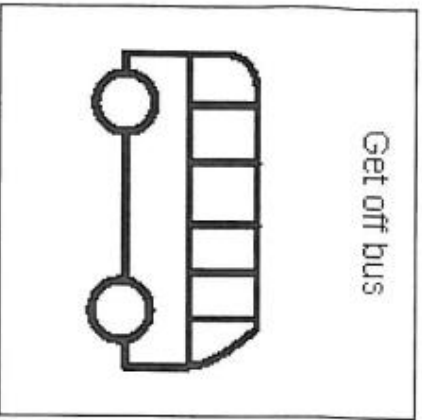

Get off bus

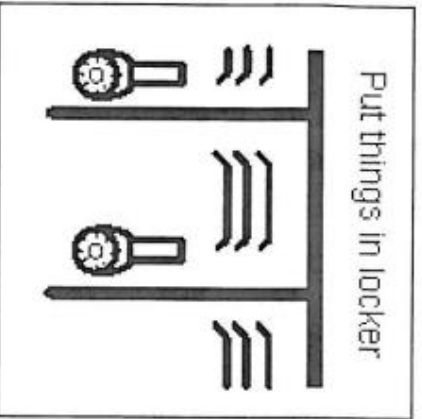

Put things in locker



Put things in box

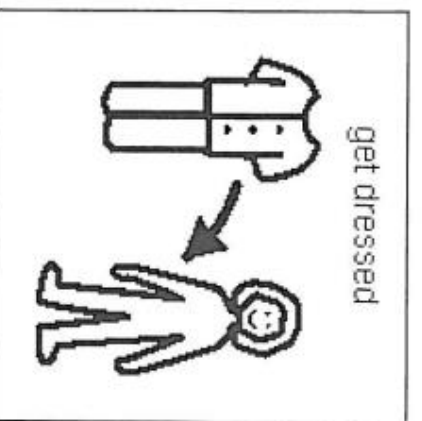

get dressed

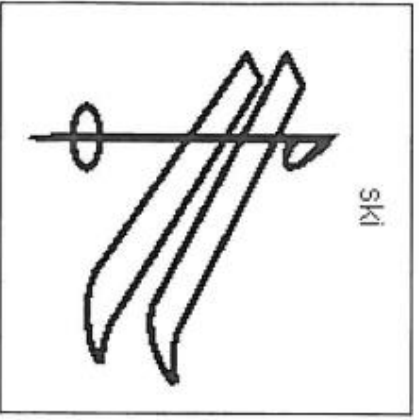

ski

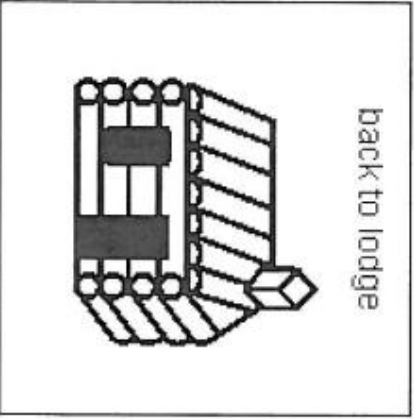

back to lodge

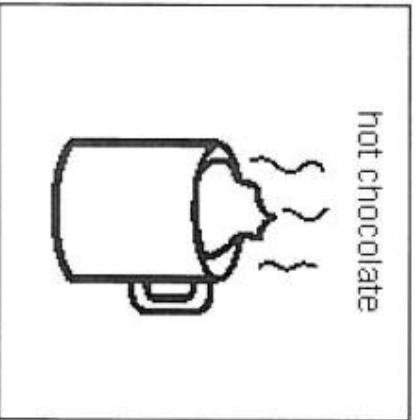

hot chocolate

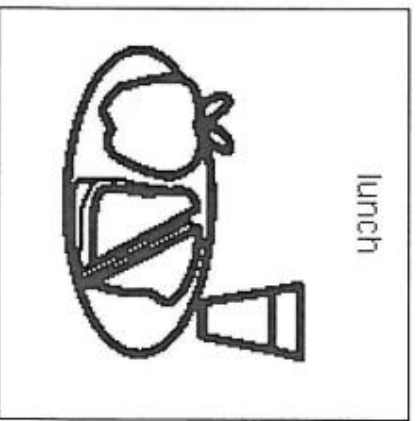

lunch

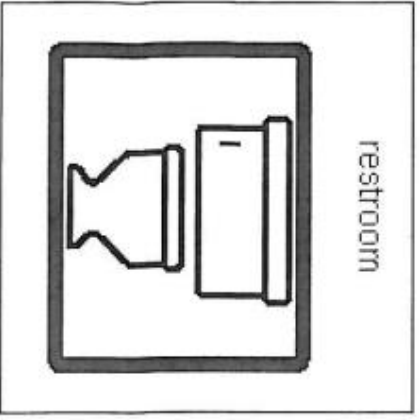

restroom

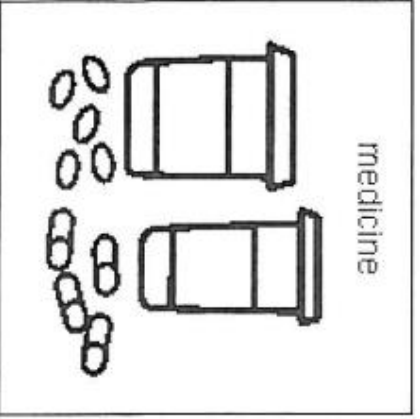

medicine

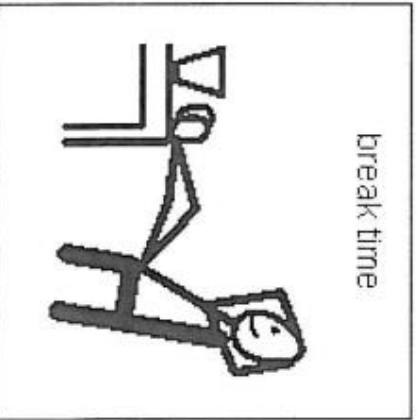

break time

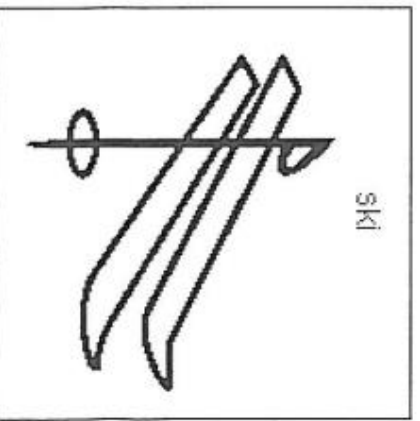

ski

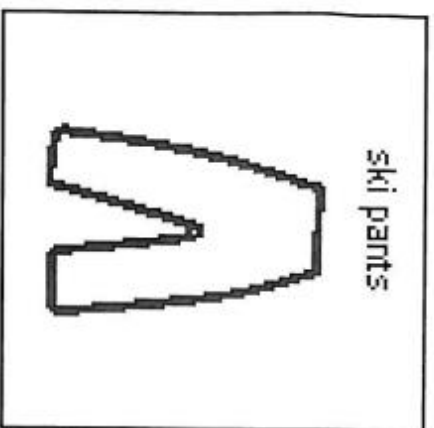

ski pants

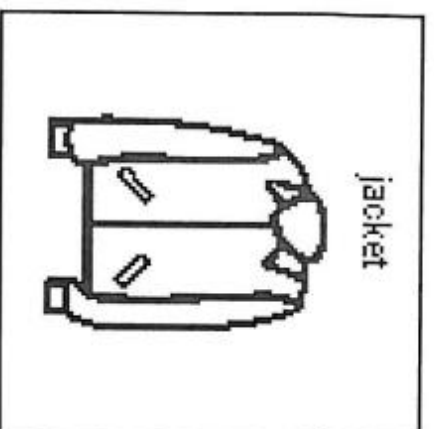

jacket

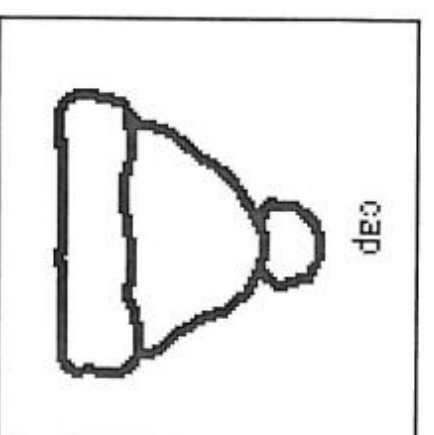

cap

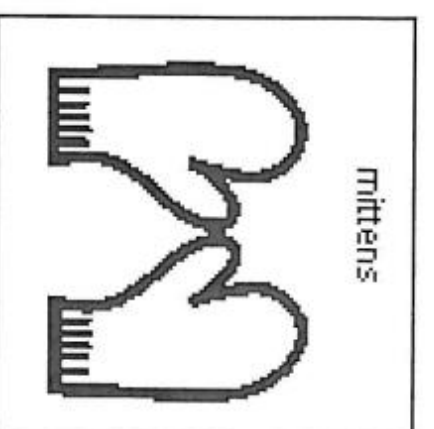

mittens

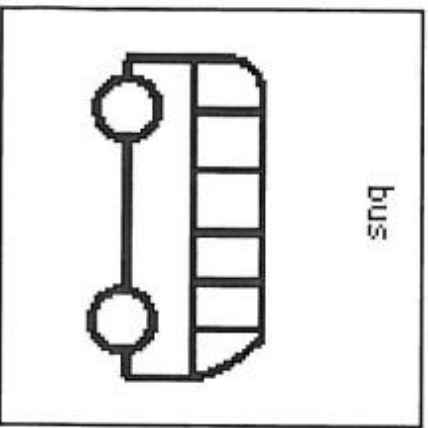

bus

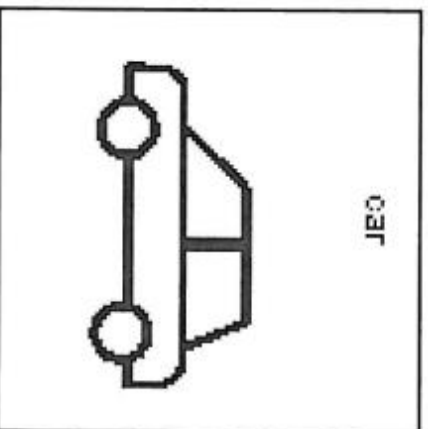

car

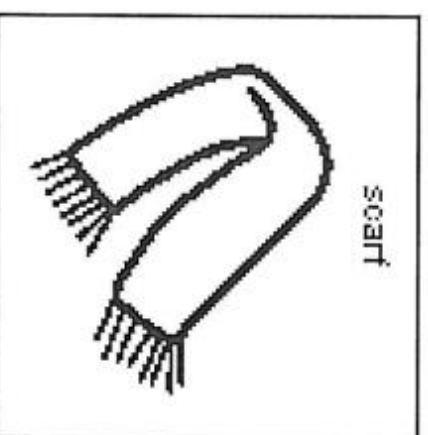

scarf

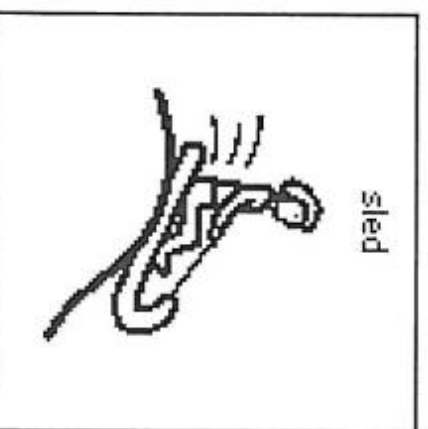

sled

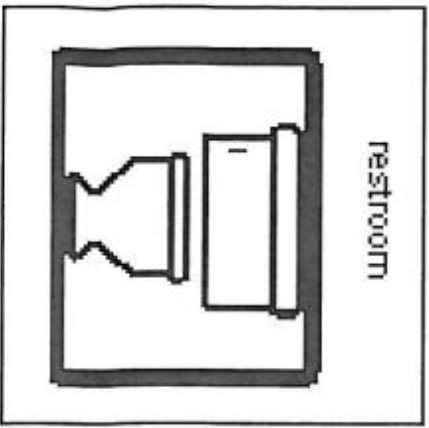

restroom

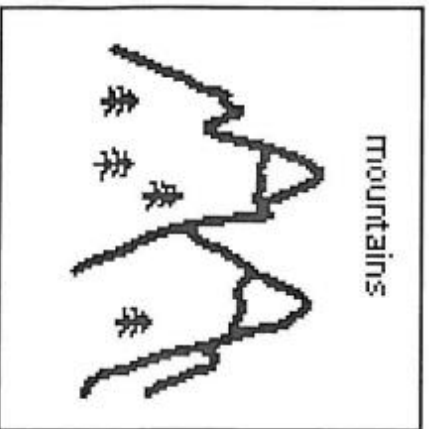

mountains

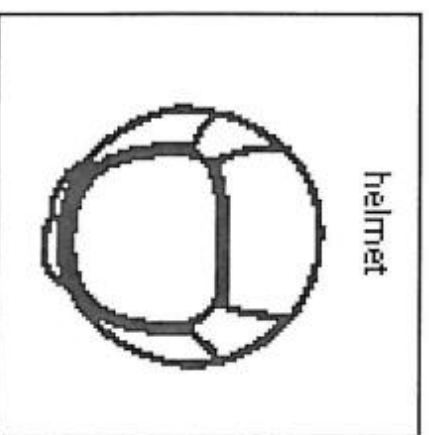

helmet

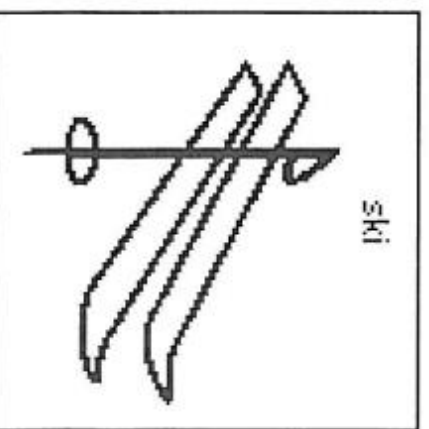

ski